

The GaGe Razor™ family of multi-channel digitizers features up to 4 channels in a single-slot PCI Express or PCI card with 200 MS/s sampling per channel, and up to 32 GB of on-board acquisition memory.

Combine several Razor cards for up to 32 channels in a single system.

APPLICATIONS

Radar Design and Test
Disk Drive Testing
Manufacturing Test
Signal Intelligence
Lidar Systems
Communications
Non-Destructive Testing
Spectroscopy
High-Performance Imaging
Ultrasound Test

Razor CompuScope 14X2

14-Bit Family of Multi-channel Digitizers for the PCI Express or PCI Bus



The 14-bit Razor CompuScope Family provides high resolution and high speed on a PCI Express or PCI card:

FEATURES

- 2 or 4 digitizing channels
- 200 MS/s maximum sampling per channel
- 14 bits vertical resolution
- 128 MS to 16 GS on-board acquisition memory
- 125 MHz bandwidth
- Full-size, single-slot PCI card
- Full-featured front-end, with software control over input ranges, coupling and impedances
- 32 bits, 66 MHz PCI for 200 MB/s transfer to PC memory
- Ease of integration with External or Reference Clock In and Clock Out, External Trigger In and Trigger Out
- Programming-free operation with GageScope® oscilloscope software
- Software Development Kits available for LabVIEW, MATLAB, C/C#
- Dual-port memory and data streaming at up to 3.1 GB/s on PCI Express models
- Custom FPGA firmware available

Razor CompuScope 14X2 Simplified Block Diagram

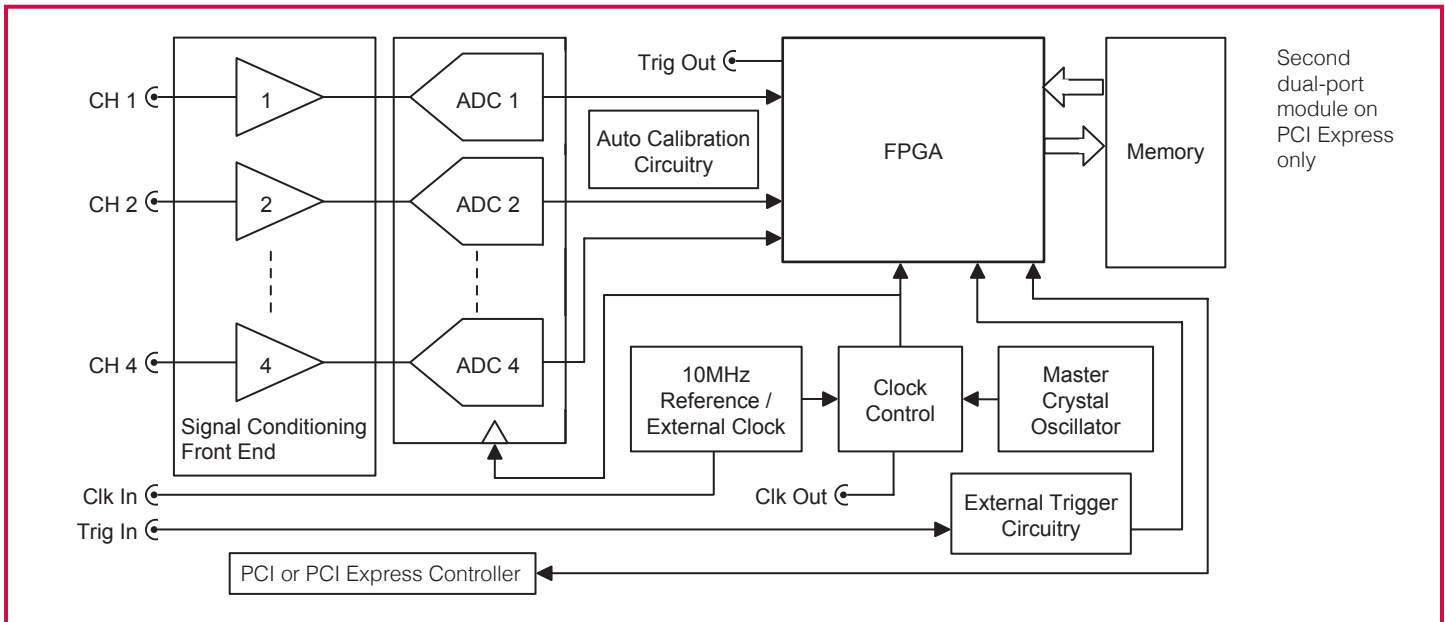

A/D SAMPLING

Number of Inputs: 2 or 4
Resolution: 14 bits

Dynamic Parameters (see Note 1):

SNR	68.3 dB
THD	-77.2 dB
SINAD	67.8 dB
ENOB (SINAD)	11.0
SFDR	83.2 dB
Noise Floor	-110.6 dB

Maximum Sampling Rate Per Channel: 200 MS/s
Sampling Rates: 200 MS/s, 100 MS/s, 50 MS/s, 25 MS/s, 10 MS/s, 5 MS/s, 2 MS/s, 1 MS/s, 500 kS/s, 200 kS/s, 100 kS/s, 50 kS/s, 20 kS/s, 10 kS/s, 5 kS/s, 2 kS/s, 1 kS/s
Connector: SMA
Impedance: 1 M Ω or 50 Ω ; (software-selectable)
Coupling: AC or DC; (software-selectable)
AC Coupled Bandwidth(1M Ω): 10 Hz to 65 MHz
DC Coupled Bandwidth(50 Ω): DC to 125 MHz
Flatness (see Note 2): Within ± 0.5 dB of ideal response 50/100 MHz
DC Accuracy (see Note 3): ± 0.5 %
Input Voltage Ranges: ± 100 mV, ± 200 mV, ± 500 mV, ± 1 V, ± 2 V, ± 5 V, ± 10 V, ± 20 V, ± 50 V (3 highest ranges only available on 1 M Ω)
DC User Offset: $\pm 1 \times$ Full Range (above ± 5 V is limited to ± 2.5 V)

Absolute Max Input: ± 15 V (50 Ω), ± 75 V (1 M Ω on all but two lowest Input Ranges, where Max is ± 25 V)

LOW-PASS FILTER

Type: 3-pole, 1 per channel
Cut-off Frequency: 25 MHz
Operation: Individually software-selectable

ACQUISITION MEMORY

Available acquisition memory: (Total on-board memory)/(# of active channels)

TRIGGERING

Trigger Engines: 2 per channel, 1 for external trigger
Source: CH 1 to 4, EXT or Software
Input Combination: All combinations of sources logically OR'ed
Trigger Level Accuracy: Less than $\pm 2\%$ of Full Scale for channel triggering
Slope: Positive or Negative; software-selectable
Sensitivity: $\pm 2\%$ of Full Scale
This implies that signal amplitude must be at least 4% of full scale to cause a trigger to occur. Smaller signals are rejected as noise.
Post-Trigger Data: 32 points minimum.
Can be defined with a 32 point resolution.

EXTERNAL TRIGGER

Impedance: 2 k Ω
Amplitude: Absolute maximum ± 15 V
Voltage Range: ± 1 V, ± 5 V (software-selectable)
Bandwidth: > 100 MHz
Coupling: AC or DC
Connector: SMA

TRIGGER OUT

Impedance:	50 Ω compatible
Amplitude:	0-1.8 V
Connector:	SMA

INTERNAL CLOCK

Accuracy:	± 1 ppm (0 to 50°C ambient)
-----------	---------------------------------

EXTERNAL CLOCK

Maximum Frequency:	Maximum Razor sample rate
Minimum Frequency:	10 MHz
Signal Level:	Minimum 1 V RMS Maximum 2 V RMS
Termination Impedance:	50 Ω
Duty Cycle:	50% $\pm 5\%$
Connector:	SMA
Coupling:	AC

EXTERNAL REFERENCE

The External Reference timebase is used to synchronize the Internal Sampling Clock

Frequency:	10 MHz ± 1000 ppm; (software-selectable)
Signal Level:	Minimum 1 V RMS Maximum 2 V RMS
Impedance:	50 Ω
Duty Cycle:	50% $\pm 5\%$
Connector:	SMA
Coupling:	AC

CLOCK OUT

Maximum Frequency:	Maximum product sample rate
Minimum Frequency:	10 MHz (from External Clock) 1 kHz (from Internal Clock)
Signal Level:	0-1.8 V
Impedance:	50 Ω compatible
Duty Cycle:	50% $\pm 10\%$
Connector:	SMA

MULTIPLE RECORD

Pre-trigger Data:	Up to virtually full record length
Record Length:	32 points minimum. Can be defined with a 32 points resolution.

TIMESTAMPING

Resolution:	One sampling interval
Counter turnover:	>48 hours continuous

CARD SIZE

Single-slot, full-length PCI Express (8 Lane) or PCI

SYSTEM REQUIREMENTS

PC computer, minimum Pentium II 500 MHz, with at least one free full-length PCI or PCI Express (8 or 16 Lane) slot, 128 MB RAM, 200 MB of free hard disk space.

†POWER (IN WATTS, PER CARD)

25.0 W (typical)

†Measured on a typical 4-channel Razor card.

BUS INTERFACE

	CS14X2 (PCI)	CSE14X2 (PCI Express)
Plug-&-Play	Fully supported	Fully supported
Bus Mastering	Fully supported	Fully supported
Scatter-Gather:	Fully supported	Fully supported
Bus Width:	32-bits	8 Lanes
Bus Speed:	66 MHz or 33 MHz	40 Gb (Gen2) or 20 Gb (Gen1)
Bus Throughput:	200 MB/s to PC memory (66 MHz PCI; dependent on motherboard and configuration)	3.1 GB/s (Gen2) or 1.6 GB/s (Gen1)
Compatibility:	PCI-compliant, v.2.2. Also v.2.1 systems that supply 3.3 V to PCI slot	PCI Express 2.0 compliant (Also 1.1 at 20 Gb)

MULTI-CARD SYSTEMS

Operating Mode:	Master/Slave or multiple independent
Number of Cards:	Master/Slave: 2 to 8 cards Multiple/Independent: Limited only by backplane and power supply

OPERATING SYSTEMS

Windows Vista/ Win 7:	All Versions (32/64-bit)
Windows XP:	SP1 or higher (32/64-bit)
Windows Server:	2003, 2008

APPLICATION SOFTWARE

GageScope: Windows-based software for programming-free operation	
LITE Edition:	Included with purchase, provides basic functionality
Standard Edition:	Provides limited functionality of advanced analysis tools, except for Extended Math
Professional Edition:	Provides full functionality of all advanced analysis tools

SOFTWARE DEVELOPMENT KITS (SDK)

CompuScope SDK for C/C# for Windows*	
CompuScope SDK for MATLAB for Windows	
CompuScope SDK for LabVIEW for Windows	

*C/C# SDK is CLR compatible and is compatible with LabWindows/CVI 7.0+ compiler.



Visual Basic.NET support available with purchase of C/C# SDK.
 Contact your GaGe Sales Agent for information on Linux support.

ORDERING INFORMATION

Hardware & Upgrades

CS14X2	PCI CompuScopes		PCI Express CompuScopes	
	2 Channel	4 Channel	2 Channel	4 Channel
	CS1422: RAZ-002-300	CS1442: RAZ-004-300	CSE1422: RZE-002-300	CSE1442: RZE-004-300
	Memory Upgrade: 128 MS to 256 MS	RAZ-181-001	Memory Upgrade: 1 GS to 2 GS	MEM-181-001
	Memory Upgrade: 128 MS to 512 MS	RAZ-181-003	Memory Upgrade: 1 GS to 4 GS	MEM-181-003
	Memory Upgrade: 128 MS to 1 GS	RAZ-181-005	Memory Upgrade: 1 GS to 8 GS	MEM-181-005
	Memory Upgrade: 128 MS to 2 GS	RAZ-181-007	Memory Upgrade: 1 GS to 16 GS	MEM-181-007

Cables

Set 1 Cable SMA to BNC ACC-001-031
 Set 4 Cable SMA to BNC ACC-001-033

Upgrades

Master Multi-Card Upgrade RAZ-181-002
 Slave Multi-Card Upgrade RAZ-181-003

eXpert™ Firmware Options

eXpert Signal Averaging Firmware Option 250-181-001

GageScope® Software

GageScope: Lite Edition Included
 GageScope: Standard Edition 300-100-351
 (with Purchase of CompuScope Hardware)
 GageScope: Professional Edition 300-100-354
 (with Purchase of CompuScope Hardware)

Software Development Kits (SDKs)

GaGe SDK Pack on CD 200-113-000
 CompuScope SDK for C/C# 200-200-101
 CompuScope SDK for MATLAB 200-200-102
 CompuScope SDK for LabVIEW 200-200-103
 eXpert Data Streaming (PCI Express Only) STR-181-000

WARRANTY

One year parts and labor
 Certificate of NIST Traceable Calibration is included.
 All specifications subject to change without notice.

Notes to specifications:

- 1) Dynamic parameter measurements were done by acquiring a high purity 10 MHz sine wave with an amplitude of 95% of the Input Range. These measurements were taken on the +/-500 mV Input Range using 50 Ohm termination and DC coupling and the anti-aliasing filter was applied. Dynamic parameter calculations were done from a 16 kiloSample Fourier Spectrum after applying a 7-term Blackman Harris Windowing Function to the time-domain waveform.
- 2) Measured at 100 MS/s in the ±500 mV range with 50 Ω input impedance with an amplitude of 95% of full scale.
- 3) Measured on ±500 mV, ±1 V, ±2 V input ranges for both 50 Ω and 1 MΩ input impedance settings.

Updated June 14, 2011
 Copyright © 2011 Gage Applied Technologies. All rights reserved.

900 N. State St.
 Lockport, IL 60441-2200

Toll-Free (US and Canada):

phone 1-800-567-4243
 fax 1-800-780-8411

Direct:

phone +1-514-633-7447
 fax +1-514-633-0770

Email:

prodinfo@gage-applied.com

To find your local sales representative or distributor or to learn more about GaGe products visit:

www.gage-applied.com